

KIT FEATURES

- ▶ Rear support provisions

KIT COMPONENTS

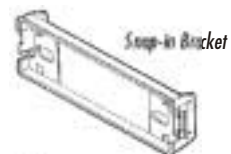

TOOLS REQUIRED



Phillips screwdriver



Cutting tool



86-5618 or AW-FDRT
Head unit removal keys

99-5512 AW-551FD INSTALLATION INSTRUCTIONS

APPLICATIONS

**FORD/JEEP/LINCOLN/MAZDA/MERCURY 1975-00
VEHICLES WITH STANDARD DIN RADIO OPENINGS
(SEE INSIDE FOR SPECIFIC APPLICATIONS)**



TABLE OF CONTENTS

CAR	PAGE	CAR	PAGE	CAR	PAGE
FORD					
Aerostar 1992-97.....	1	ALFA ROMEO		MITSUBISHI	
Aspire 1994-97.....	1	Milano 1980-89.....	12	Mighty Max 1987-95.....	12
Bronco 1992-96.....	4	Spider Veloce 1987-93.....	12	Mirage 1993-96.....	12
Bronco II 1989-90.....	2	164 L/S 1991-93.....	12	PEUGEOT	
Contour 1995-00.....	2	AUDI		405 1989-93.....	12
Crown Victoria 1991-94.....	3	80/90 1988-96.....	12	505 1984-93.....	12
Econoline 1992-96.....	3	100/200 1989-95.....	12	PONTIAC	
Escort 1991-96.....	4	4000 1980-87.....	12	LeMans 1988-93.....	12
Explorer 1991-94.....	2	5000 1978-88.....	12	PORSCHE	
F-Series Pickup 1992-96.....	4	S4 1992-93.....	12	911 1973-96.....	12
Mustang 1994-00.....	5	BMW		924 1977-82.....	12
Probe 1993-97.....	5	3-Series 1977-96.....	12	924S 1986-88.....	12
Ranger (mini) 1989-94.....	2	5-Series 1975-96.....	12	928 1980-96.....	12
Taurus 1990-95.....	6	6-Series 1977-89.....	12	944 1986-93.....	12
Tempo 1989-94.....	6	7-Series 1978-96.....	12	968 1992-96.....	12
Thunderbird 1989-97.....	7	8-Series 1991-93.....	12	RENAULT	
Windstar 1995-98.....	7	DAIHATSU		Alliance 1984-85.....	12
LINCOLN					
Continental 1988-94.....	8	Charade 1989-92.....	12	Encore 1984-85.....	12
Mark VII 1990-92.....	8	DODGE		Fuego 1982-85.....	12
Mark VIII 1993-95.....	8	Colt 1993-94.....	12	LeCar 1976-83.....	12
Town Car 1990-94.....	8	D50 Pickup 1988-93.....	12	18i 1979-83.....	12
MAZDA					
B-Series Pickup 1994.....	2	EAGLE		SAAB	
626 1993-00.....	10	Summit 1993-95.....	12	900 1979-96.....	12
MPV 1996-98.....	9	FIAT		9000 1986-96.....	12
MX3 1992-96.....	9	Brava 1979-83.....	12	STERLING	
MX6 1993-97.....	10	Spider 1988-89.....	12	825 1987-88.....	12
Navajo 1991-94.....	2	Strada 1977-83.....	12	827 1989-92.....	12
Protege 1995-00.....	10	X19 1979-89.....	12	SUZUKI	
MERCUY					
Capri XR2 1991-94.....	11	GEO		Samurai 1988½-93.....	12
Cougar 1989-97.....	7	Metro 1989-91.....	12	Sidekick 1989-91.....	12
Grand Marquis 1991-94.....	3	Tracker 1989-91.....	12	Swift 1989-91.....	12
Mystique 1995-99.....	2	HONDA		X-90 1996-97.....	12
Sable 1990-95.....	6	Accord 1982-89.....	12	VOLKSWAGEN	
Topaz 1989-94.....	6	CRX 1984-91.....	12	Bus 1968-79.....	12
Tracer 1991-96.....	4	Civic 1982-95.....	12	Cabriolet 1985-93.....	12
Villager 1993-95.....	12	Del Sol 1993-96.....	12	Dasher 1976-81.....	12
NISSAN					
Quest 1993-95.....	12	Prelude 1983-91.....	12	Fox 1987-93.....	12
ADDITIONAL VEHICLES:					
ACURA					
Integra 1986-89.....	12	JAGUAR		Golf 1985-98.....	12
Legend 1986-89.....	12	XJ6 1988-93.....	12	Passat 1990-99.....	12
MASERATI					
MERCEDES					
Spyder 1985-90..... 12					
240/280/300/380/420/450					
500SLC/SEL 1970-96..... 12					

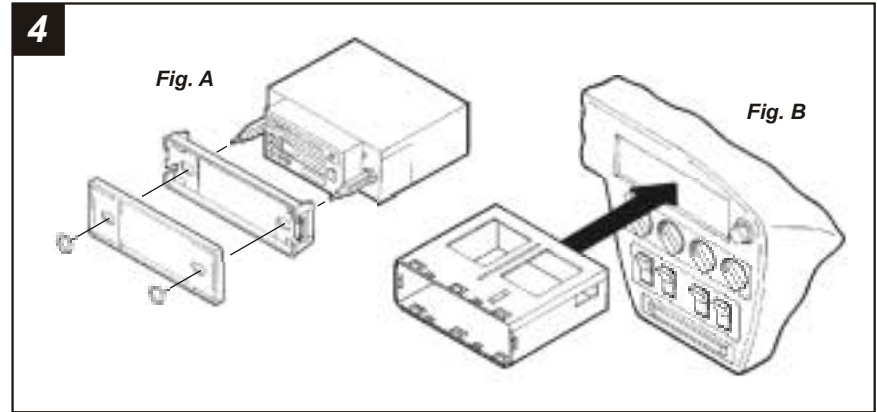

2-SHAFT HEAD UNITS: Attach the **Faceplate** to the **Snap-in Bracket**. (If an aftermarket unit with upper-shaft locations is being installed, cut and remove the upper-shaft tabs from the shaft holes in the Snap-in Bracket). Slide the aftermarket head unit into the kit and secure with shaft nuts. (see Fig. A)

DIN HEAD UNITS: Slide the DIN cage into the dash opening and secure by bending the metal locking tabs down. Be sure the **Rear Support Bracket** engages the support shelf in the dash. (see Fig. B)

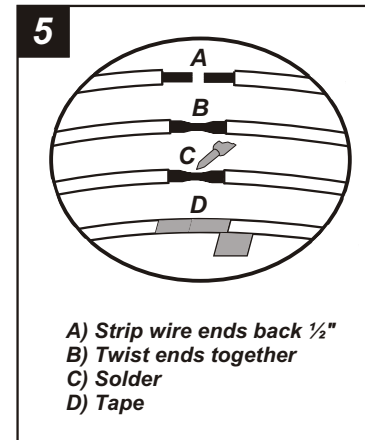

Locate the factory wiring harness in the dash. Metra recommends using the proper mating adaptor and making connections as shown. (Isolate and individually tape off the ends of any unused wires to prevent electrical short circuit).

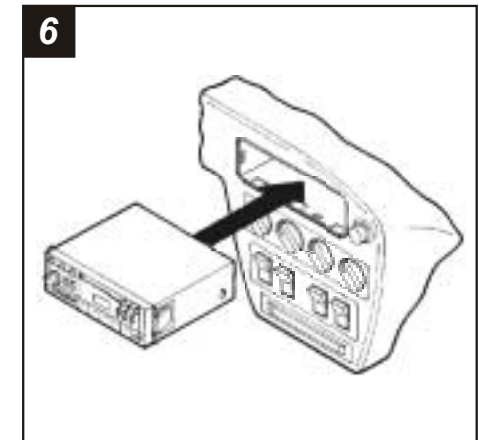

Re-connect the battery terminal and test the unit for proper operation.

2-SHAFT HEAD UNITS: Snap the head unit/kit assembly into the dash opening. (Be sure the **Rear Support Bracket** engages the support shelf in the dash).

DIN HEAD UNITS: Slide the aftermarket head unit into the mounted cage until secure.

MERCURY Villager / NISSAN Quest 1993-95



1 Disconnect the negative battery terminal to prevent an accidental short circuit. Remove (1) screw above the climate controls. Unclip the dash trim bezel. Using Metra's **86-5618** or **AW-FDRT**, pull the factory head unit from the dash and disconnect the wiring.

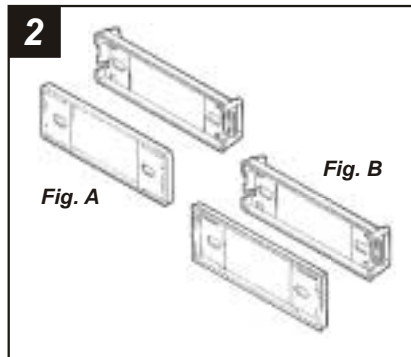

2 Locate the **Snap-in Bracket** and **Rounded Faceplate** (see Fig. A) OR the **Snap-in Bracket** and **Cornered Faceplate** (see Fig. B). Skip to the Installation Instructions for ALL VEHICLES on Page #12.

FORD Aerostar 1992-97

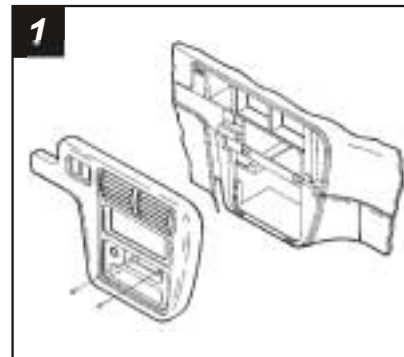

1 Disconnect the negative battery terminal to prevent an accidental short circuit. Remove (2) screws from the steering column trim panel and (2) screws from the ashtray cavity. Unclip the dash trim bezel. Using Metra's **86-5618** or **AW-FDRT**, pull the factory head unit from the dash and disconnect the wiring.

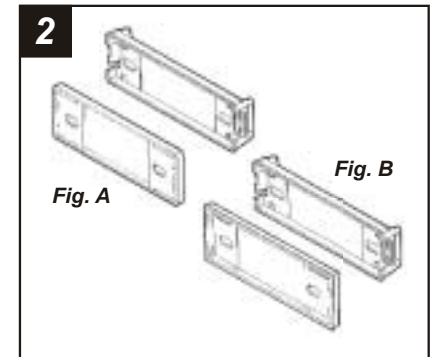

2 Locate the **Snap-in Bracket** and **Rounded Faceplate** (see Fig. A) OR the **Snap-in Bracket** and **Cornered Faceplate** (see Fig. B). Skip to the Installation Instructions for ALL VEHICLES on Page #12.

ALL VEHICLES

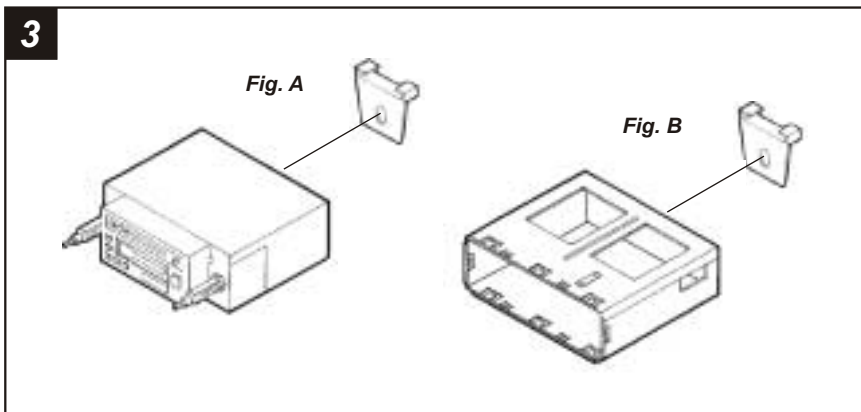

2-SHAFT HEAD UNITS: Mount the **Rear Support Bracket** to the back of the aftermarket head unit with the necessary hardware. (see Fig. A)

DIN HEAD UNITS: Mount the **Rear Support Bracket** to the back of the aftermarket DIN cage with the necessary hardware. (see Fig. B)

FORD Aspire 1994-97

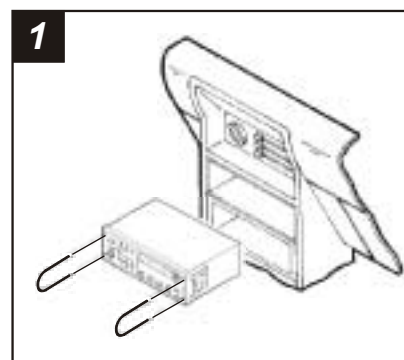

1 Disconnect the negative battery terminal to prevent an accidental short circuit. Using Metra's **86-5618** or **AW-FDRT**, pull the factory head unit from the dash and disconnect the wiring.

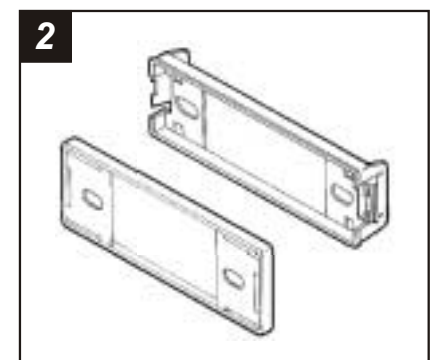

2 Locate the **Snap-in Bracket** and **Rounded Faceplate**. Skip to the Installation Instructions for ALL VEHICLES on Page #12.

**FORD Bronco II 1989-90 / Explorer 1991-94 / Ranger 1989-94
MAZDA Navajo 1991-94 / B-Series Pickup 1994**

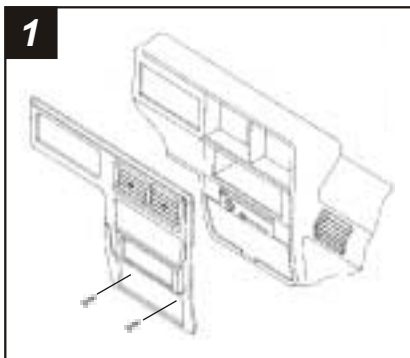

1
Disconnect the negative battery terminal to prevent an accidental short circuit. Remove the ashtray and (2) screws exposed in the ashtray cavity. Using Metra's **86-5618** or **AW-FDRT**, pull the factory head unit from the dash and disconnect the wiring.

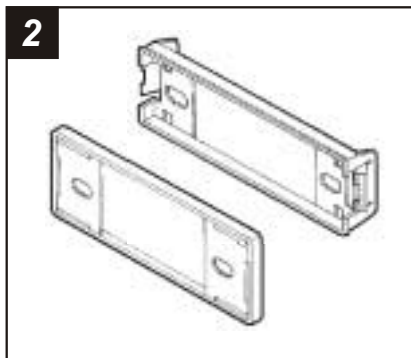

2
Locate the **Snap-in Bracket** and **Rounded Faceplate**. Skip to the *Installation Instructions for ALL VEHICLES on Page #12*.

FORD Contour 1995-00 / MERCURY Mystique 1995-99

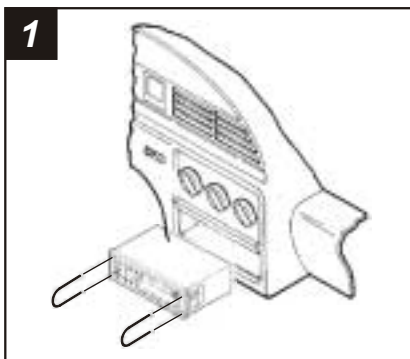

1
Disconnect the negative battery terminal to prevent an accidental short circuit. Using Metra's **86-5618** or **AW-FDRT**, pull the factory head unit from the dash and disconnect the wiring.

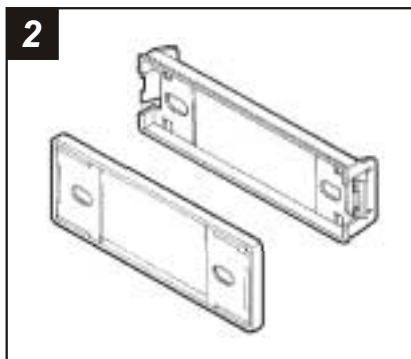

2
Locate the **Snap-in Bracket** and **Rounded Faceplate**. Skip to the *Installation Instructions for ALL VEHICLES on Page #12*.

MERCEDES (all models)

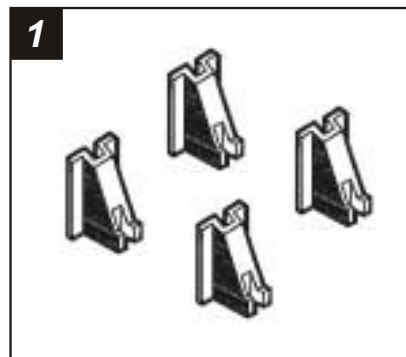

1
Locate the (4) **Locking Tabs** supplied in the kit.

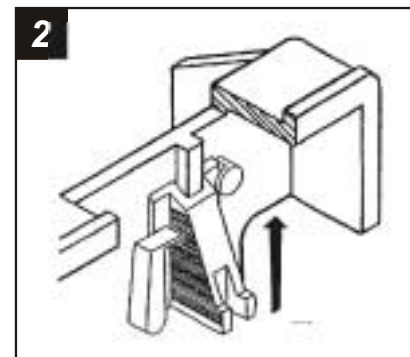

2
Slide the **Locking Tabs** onto the guides located on the front corners of the **Snap-in Bracket**. Skip to the *Installation Instructions for ALL VEHICLES on Page #12*.

MERCURY Capri XR2 1991-94

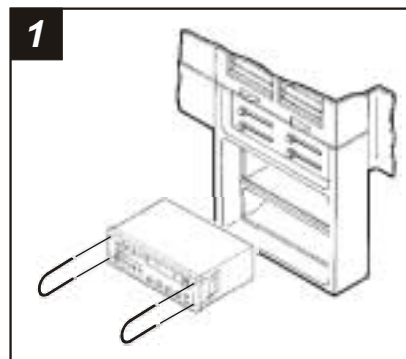

1
Disconnect the negative battery terminal to prevent an accidental short circuit. Using Metra's **86-5618** or **AW-FDRT**, pull the factory head unit from the dash and disconnect the wiring.

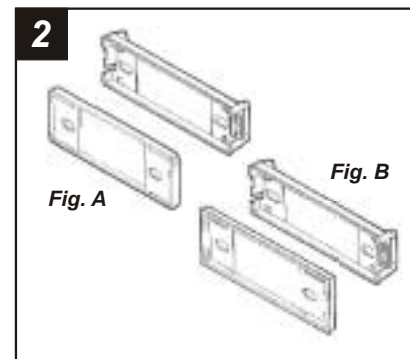

2
Locate the **Snap-in Bracket** and **Rounded Faceplate** (see Fig. A) OR the **Snap-in Bracket** and **Cornered Faceplate** (see Fig. B). Skip to the *Installation Instructions for ALL VEHICLES on Page #12*.

MAZDA MX6 1993-97 / 626 1993-00

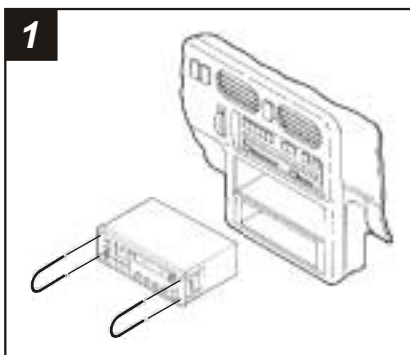

1
Disconnect the negative battery terminal to prevent an accidental short circuit. Using Metra's **86-5618** or **AW-FDRT**, pull the factory head unit from the dash and disconnect the wiring.

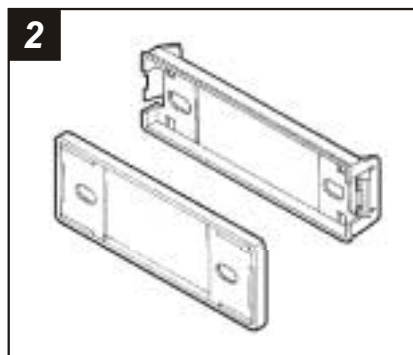

2
Locate the **Snap-in Bracket** and **Rounded Faceplate**. Skip to the *Installation Instructions for ALL VEHICLES on Page #12*.

MAZDA Protege 1995-00

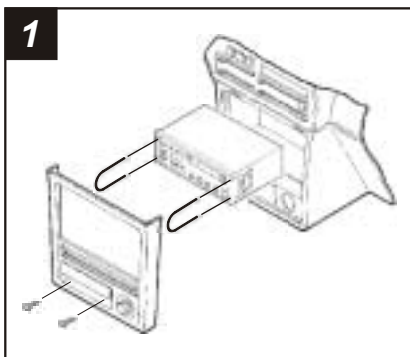

1
Disconnect the negative battery terminal to prevent an accidental short circuit. Remove the ashtray and (2) screws from the ashtray cavity. Using Metra's **86-5618** or **AW-FDRT**, pull the factory head unit from the dash and disconnect the wiring.

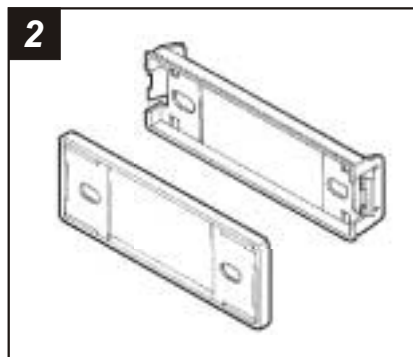

2
Locate the **Snap-in Bracket** and **Rounded Faceplate**. Skip to the *Installation Instructions for ALL VEHICLES on Page #12*.

FORD Crown Victoria 1991-94 MERCURY Grand Marquis 1991-94

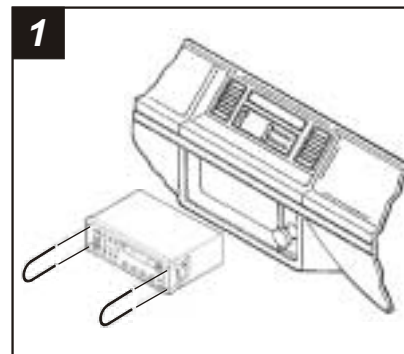

1
Disconnect the negative battery terminal to prevent an accidental short circuit. Using Metra's **86-5618** or **AW-FDRT**, pull the factory head unit from the dash and disconnect the wiring.

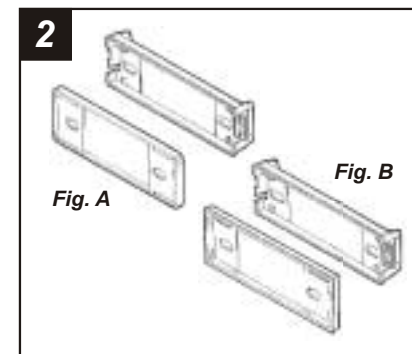

2
Locate the **Snap-in Bracket** and **Rounded Faceplate** (see Fig. A) OR the **Snap-in Bracket** and **Cornered Faceplate** (see Fig. B). Skip to the *Installation Instructions for ALL VEHICLES on Page #12*.

FORD Econoline 1992-96

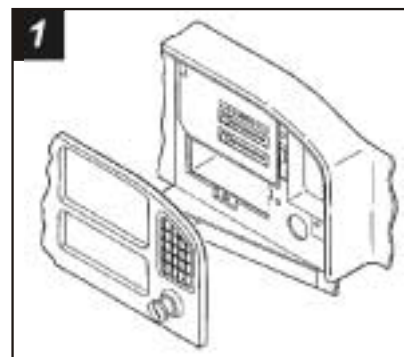

1
Disconnect the negative battery terminal to prevent an accidental short circuit. Remove the light switch knob and unscrew the surrounding trim. Remove the cupholder and the screws exposed in the cupholder cavity. Unsnap the (2) trim bezel inserts and remove the screws exposed. Remove the lower steering column trim panel and unclip the dash trim bezel. Using Metra's **86-5618** or **AW-FDRT**, pull the factory head unit from the dash and disconnect the wiring.

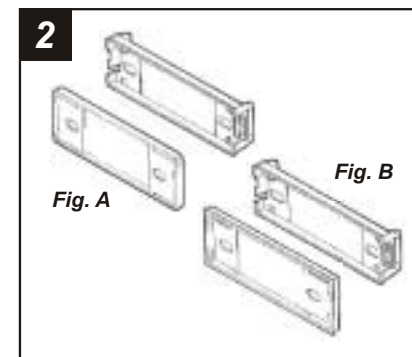

2
Locate the **Snap-in Bracket** and **Rounded Faceplate** (see Fig. A) OR the **Snap-in Bracket** and **Cornered Faceplate** (see Fig. B). Skip to the *Installation Instructions for ALL VEHICLES on Page #12*.

FORD Escort / MERCURY Tracer 1991-96

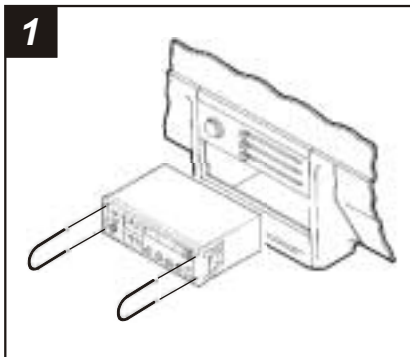

Disconnect the negative battery terminal to prevent an accidental short circuit. Using Metra's **86-5618** or **AW-FDRT**, pull the factory head unit from the dash and disconnect the wiring.

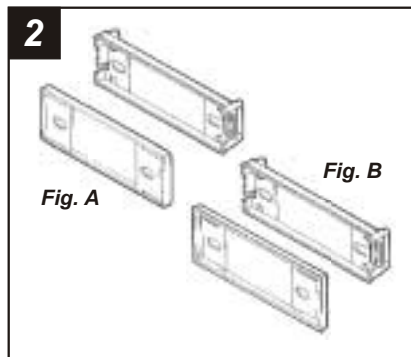

Locate the **Snap-in Bracket** and **Rounded Faceplate** (see Fig. A) OR the **Snap-in Bracket** and **Cornered Faceplate** (see Fig. B). Skip to the Installation Instructions for ALL VEHICLES on Page #12.

MAZDA MPV 1996-98

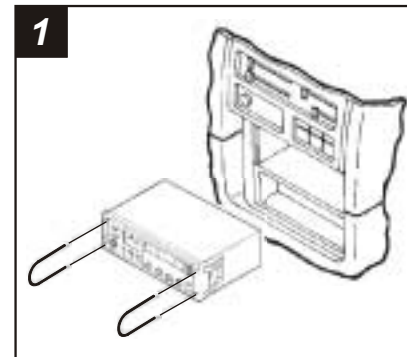

Disconnect the negative battery terminal to prevent an accidental short circuit. Unsnap the side trim pieces from the factory head unit. Using Metra's **86-5618** or **AW-FDRT**, pull the unit from the dash and disconnect the wiring.

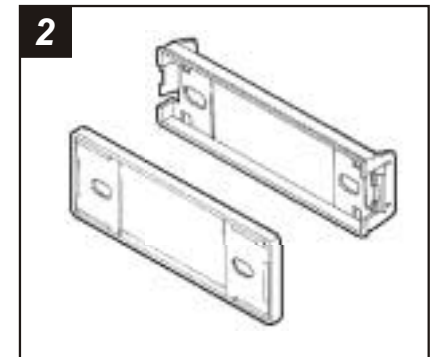

Locate the **Snap-in Bracket** and **Rounded Faceplate**. Skip to the Installation Instructions for ALL VEHICLES on Page #12.

FORD F-Series Pickup / Bronco 1992-96

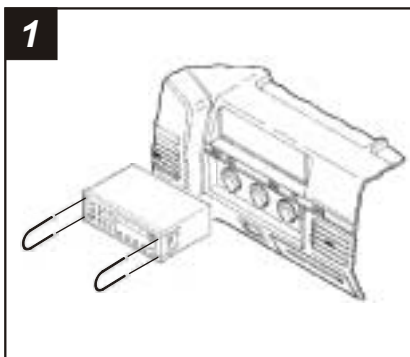

Disconnect the negative battery terminal to prevent an accidental short circuit. Using Metra's **86-5618** or **AW-FDRT**, pull the factory head unit from the dash and disconnect the wiring.

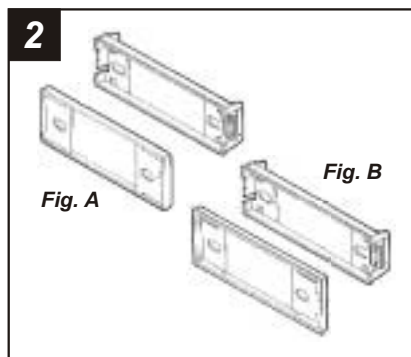

Locate the **Snap-in Bracket** and **Rounded Faceplate** (see Fig. A) OR the **Snap-in Bracket** and **Cornered Faceplate** (see Fig. B). Skip to the Installation Instructions for ALL VEHICLES on Page #12.

MAZDA MX3 1992-96

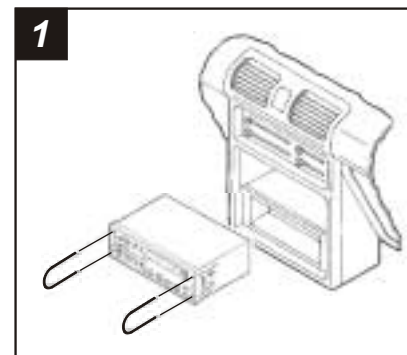

Disconnect the negative battery terminal to prevent an accidental short circuit. Using Metra's **86-5618** or **AW-FDRT**, pull the factory head unit from the dash and disconnect the wiring.

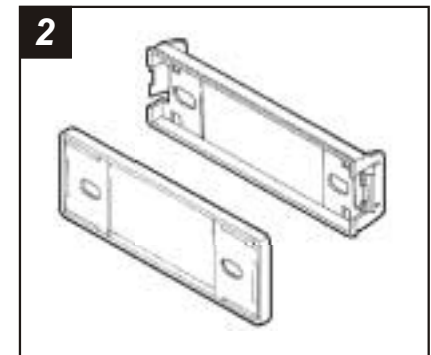

Locate the **Snap-in Bracket** and **Rounded Faceplate**. Skip to the Installation Instructions for ALL VEHICLES on Page #12.

LINCOLN Continental 1988-94 / Mark VII 1990-92 Town Car 1990-94

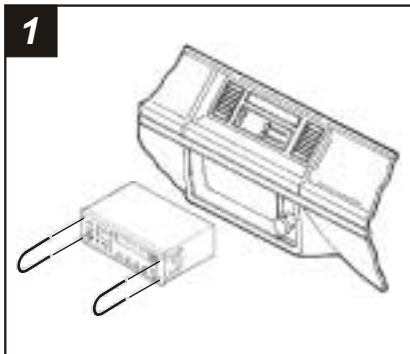

1
Disconnect the negative battery terminal to prevent an accidental short circuit. Using Metra's **86-5618** or **AW-FDRT**, pull the factory head unit from the dash and disconnect the wiring.

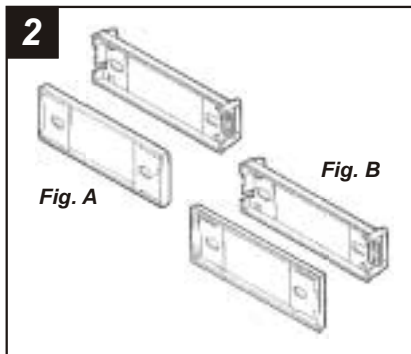

2
Locate the **Snap-in Bracket** and **Rounded Faceplate** (see Fig. A) OR the **Snap-in Bracket** and **Cornered Faceplate** (see Fig. B). Skip to the *Installation Instructions for ALL VEHICLES on Page #12*.

FORD Mustang 1994-00

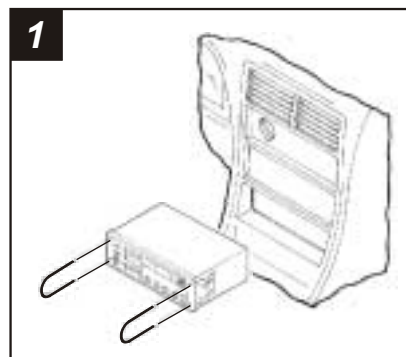

1
Disconnect the negative battery terminal to prevent an accidental short circuit. Using Metra's **86-5618** or **AW-FDRT**, pull the factory head unit from the dash and disconnect the wiring.

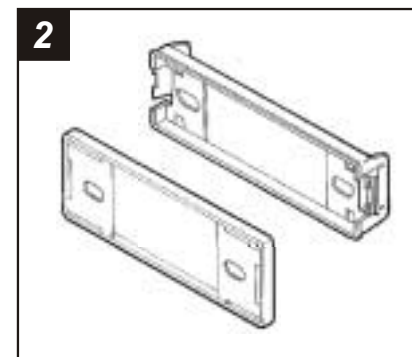

2
Locate the **Snap-in Bracket** and **Rounded Faceplate**. Skip to the *Installation Instructions for ALL VEHICLES on Page #12*.

LINCOLN Mark VIII 1993-95

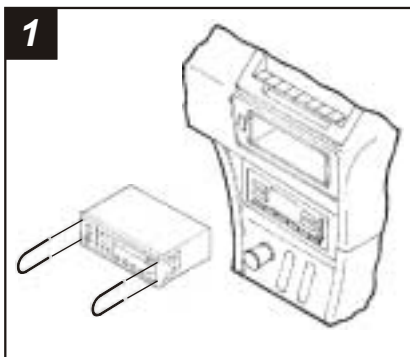

1
Disconnect the negative battery terminal to prevent an accidental short circuit. Using Metra's **86-5618** or **AW-FDRT**, pull the factory head unit from the dash and disconnect the wiring.

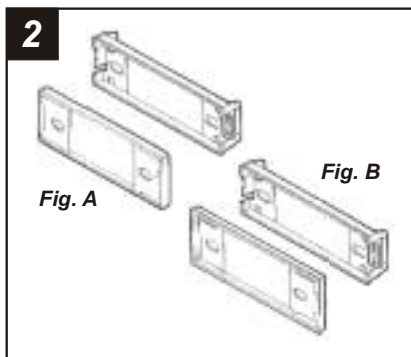

2
Locate the **Snap-in Bracket** and **Rounded Faceplate** (see Fig. A) OR the **Snap-in Bracket** and **Cornered Faceplate** (see Fig. B). Skip to the *Installation Instructions for ALL VEHICLES on Page #12*.

FORD Probe 1993-97

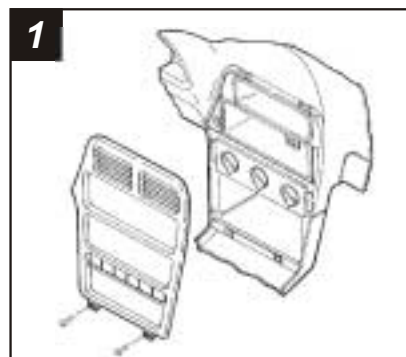

1
Disconnect the negative battery terminal to prevent an accidental short circuit. Remove (2) screws from the base of the dash trim bezel. Unclip and remove the bezel. Using Metra's **86-5618** or **AW-FDRT**, pull the factory head unit from the dash and disconnect the wiring.

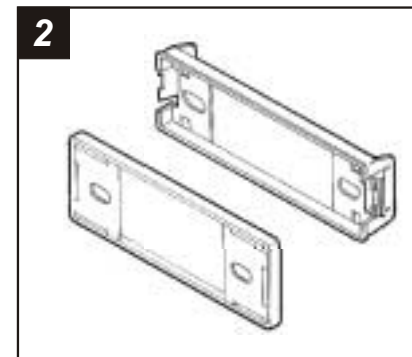

2
Locate the **Snap-in Bracket** and **Rounded Faceplate**. Skip to the *Installation Instructions for ALL VEHICLES on Page #12*.

FORD Taurus / MERCURY Sable 1990-95

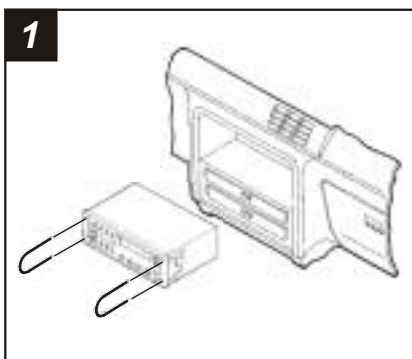

1
Disconnect the negative battery terminal to prevent an accidental short circuit. Using Metra's **86-5618** or **AW-FDRT**, pull the factory head unit from the dash and disconnect the wiring.

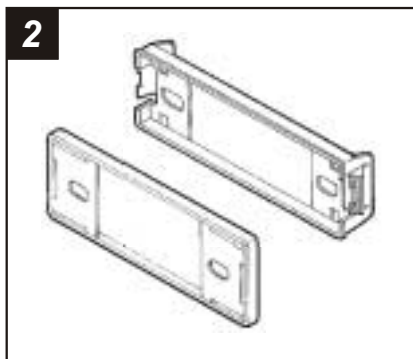

2
Locate the **Snap-in Bracket** and **Rounded Faceplate**. Skip to the Installation Instructions for ALL VEHICLES on Page #12.

FORD Thunderbird / MERCURY Cougar 1989-97

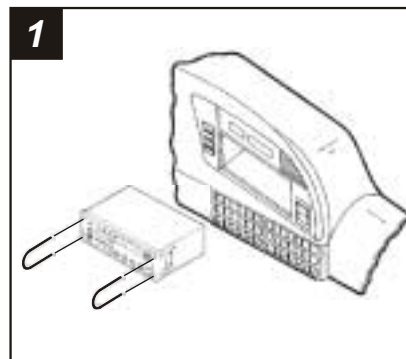

1
Disconnect the negative battery terminal to prevent an accidental short circuit. Using Metra's **86-5618** or **AW-FDRT**, pull the factory head unit from the dash and disconnect the wiring.

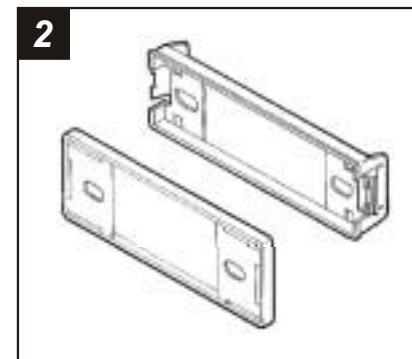

2
Locate the **Snap-in Bracket** and **Rounded Faceplate**. Skip to the Installation Instructions for ALL VEHICLES on Page #12.

FORD Tempo / MERCURY Topaz 1989-94

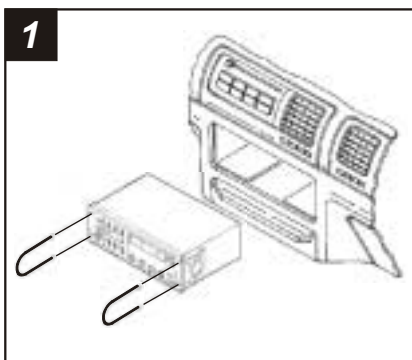

1
Disconnect the negative battery terminal to prevent an accidental short circuit. Using Metra's **86-5618** or **AW-FDRT**, pull the factory head unit from the dash and disconnect the wiring.

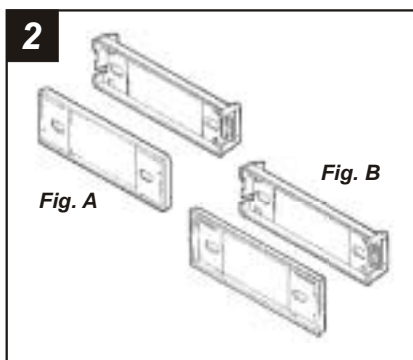

2
Locate the **Snap-in Bracket** and **Rounded Faceplate** (see Fig. A) OR the **Snap-in Bracket** and **Cornered Faceplate** (see Fig. B). Skip to the Installation Instructions for ALL VEHICLES on Page #12.

FORD Windstar 1995-98

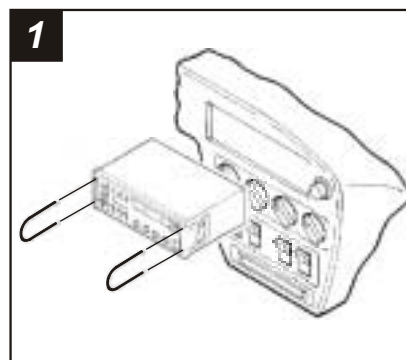

1
Disconnect the negative battery terminal to prevent an accidental short circuit. Using Metra's **86-5618** or **AW-FDRT**, pull the factory head unit from the dash and disconnect the wiring.

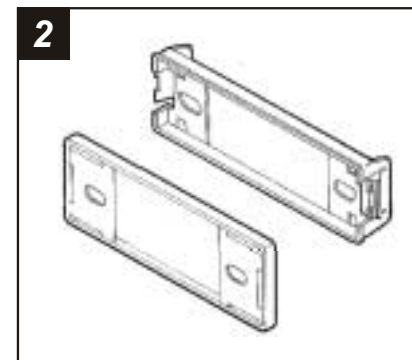

2
Locate the **Snap-in Bracket** and **Rounded Faceplate**. Skip to the Installation Instructions for ALL VEHICLES on Page #12.